



Installation Instructions and Owner's Manual

Convertible Top

The Jambo Registry
www.82jambo.com

For: JEEP® CJ7, 1976-85

Model #51008

Congratulations on your purchase of our Convertible Top. It has been designed to give you years of dependable performance if given the proper service and care. If any problems occur that cannot easily be solved, please contact our Customer Service Department at (303) 776-1630.



PLEASE READ ALL INSTRUCTIONS BEFORE INSTALLING TOP
AND KEEP THIS MANUAL FOR REFERENCE
AFTER INSTALLATION

IMPORTANT PLEASE NOTE

1. Keep your Top in a warm room until ready for installation. Installation of your Convertible Top should be done in temperatures of 70°F (21°C) or warmer! Cooler temperatures cause the fabric to contract, making for a difficult installation. Use only parts that come with this Top since old parts may not match.
2. It is normal for your Top to contract and wrinkle when stored in the shipping carton. Impressions in windows caused by shipping and handling will disappear after 48 to 72 hours of exposure to direct sunlight.

#51008

CONTENTS

Tools needed Pg. 2
 Unpacking Pg. 2
 Parts List Pg. 2
 Hardware Identification Pg. 3
 Windshield Adjustment Pg. 4
 Hardware Installation Pg. 4
 Top Fabric Installation Pg. 6
 Door Assembly Pg. 9
 Folding Top Down Pg. 10
 Repacking For Return Pg. 11
 Care and Maintenance Pg. 12

TOOLS NEEDED

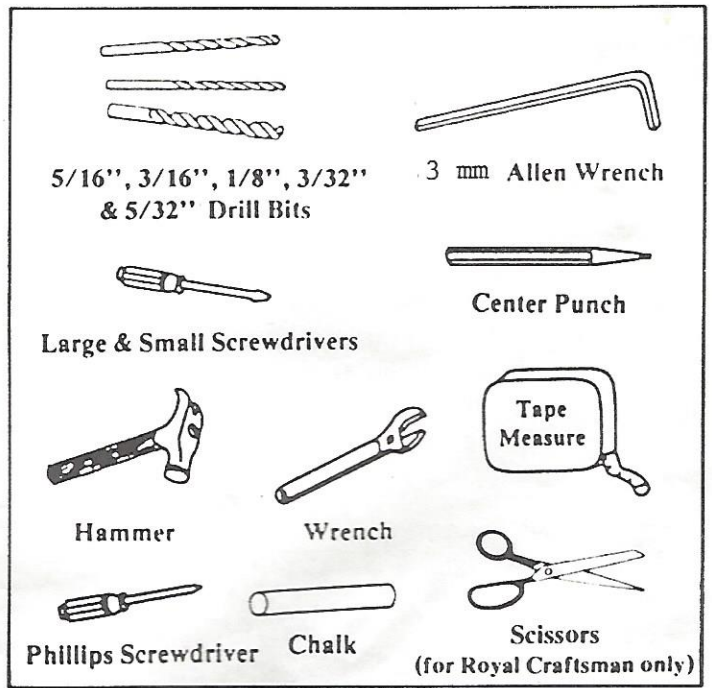

UNPACKING

Take out parts carefully so as not to scratch windows. Before you throw out any packing materials, check each part with the Parts List to make sure you have everything. If parts are missing, contact our Customer Service Department at (303) 776-1630. Save carton for later storage.

PARTS LIST

ITEM	DESCRIPTION	QTY.	PART #
1	Top Fabric/Bow Covers	1	187.95 *
2	Front Bow Set	1	153.08
3	Rear Bow Set	1	153.09
4	Vertical Rod	2	187.96
5	Left Horizontal Rod	1	187.97
6	Right Horizontal Rod	1	187.98
7	Bow Mounting Bracket	2	151.84
8	#10 Sheet Metal Screw	14	1.92
9	Clevis Pin	4	119.09
10	Hairpin Keeper	4	151.40
11	1" Plastic Rod Cap	2	151.55
12	Horizontal Rod Bracket	2	153.12
13	1½" Plastic Rod Cap	4	151.54
14	Left Vertical Rod Bracket	1	152.01
15	Right Vertical Rod Bracket	1	152.02
16	Body Stud	31	9.68
17	#6 Sheet Metal Screw	31	9.69
18	¼" Lockwasher	12	151.80

ITEM	DESCRIPTION	QTY.	PART #
19	¼" x ½" Bolt	8	116.64
20	26½" Windshield Channel	2	153.14
21	Left Door Assembly	1	136.73 *
22	Right Door Assembly	1	136.76 *
23	Left Door Pivot	2	152.76
24	Right Door Pivot	2	152.75
25	7/16" Flat Washer	4	117.28
26	Left Inside Door Handle	1	151.72
27	Right Inside Door Handle	1	152.51
28	Outside Door Handle	2	151.62
29	2½" Left Door Handle Cover	1	151.69
30	2½" Right Door Handle Cover	1	151.71
31	¼" Nut	4	3.56
32	¼" x 3/4" Bolt	4	8.116.10
33	Small Zipper Tab Cover	4	151.90
34	Large Zipper Tab Cover	2	151.89
35	3-3/8" Door Handle Cover	2	151.70

*This Part No. is for black only. If another color is required, please specify.

If you have purchased the "Royal Craftsman" Convertible Top, installation is the same with the exception of the hook-and-loop fastening system in addition to the snaps. Your Parts Kit will also include approximately 12 ft. 3 in. Pressure Sensitive Adhesive (PSA) Dual Lock.

HARDWARE IDENTIFICATION

#51008

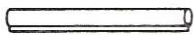

**Bow Cover
(Item 1)**

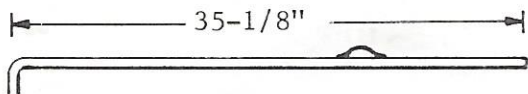

**Left Horizontal Rod
(Item 5)**

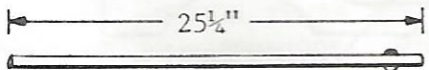

**Vertical Rod
(Item 4)**

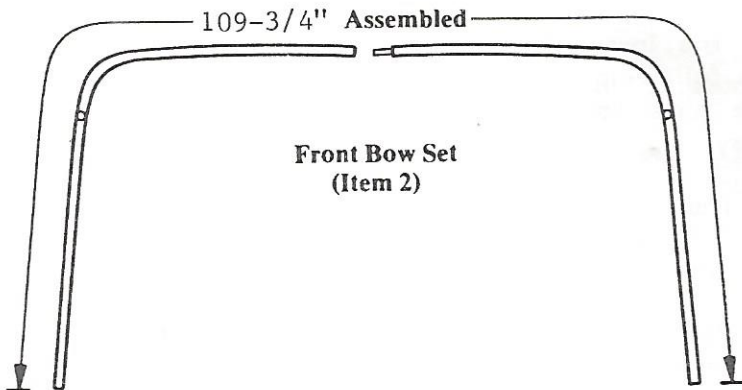

**Front Bow Set
(Item 2)**

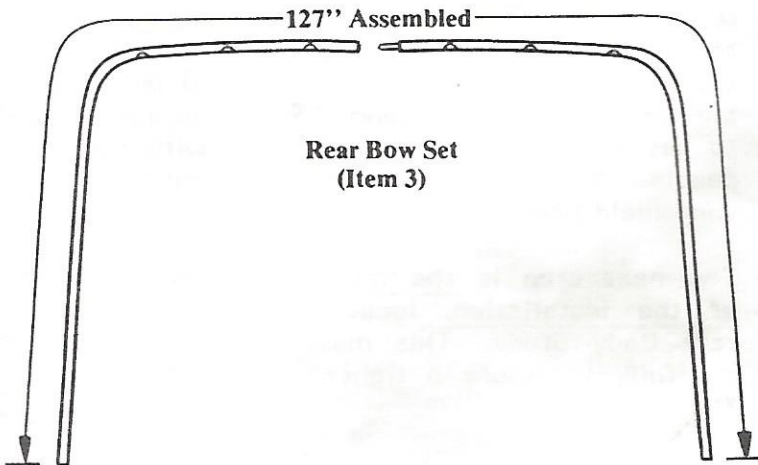

**Rear Bow Set
(Item 3)**



**Hairpin Clevis Keeper
(Item 10)**

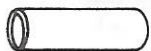

**Plastic Rod Cap
(Item 11)**



**Clevis Pin
(Item 9)**

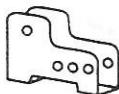

**Bow Mounting Bracket
(Item 7)**



**# 10 S/M Screw
(Item 8)**



**Horizontal Rod Bracket
(Item 12)**



**Left & Right Vertical Rod Bracket
(Items 14 & 15)**



**Body Stud
(Item 16)**



**# 6 S/M Screw
(Item 17)**



**1/4" Lock Washer
(Item 18)**

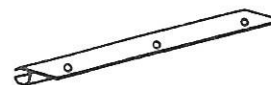

**Windshield Channel
(Item 20)**



**Bolt
(Items 19 & 32)**



**Left & Right Door Pivots
(Items 23 & 24)**



**7/16" Washer
(Item 25)**

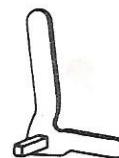

**Left Inside Door Handle
(Item 26)**



**Outside Door Handle
(Item 28)**

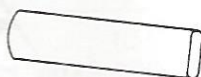

**Door Handle Cover
(Items 29, 30 & 35)**



**1/4" Nut
(Item 31)**

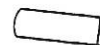

**Zipper Tab Cover
(Items 33 & 34)**

INSTALLATION INSTRUCTIONS

#51008 In the installation of your new Top you will be following the step by step instructions which we have found to be the fastest and easiest way.

- The very first thing you must do is **ADJUST THE WINDSHIELD**. It is easier if you have someone help you with this adjustment.
- You will then proceed to install all the hardware on you vehicle for the Top.
- After the hardware is in place you are ready to install Top fabric. Again, you will need the help of another person. The Top is too big for one person to handle, and it is easier to get a tight and wrinkle-free fit with two people. You will install the Top onto the windshield first.
- The next step is the most important part of the installation, locating the side and rear Body Studs. This must be done very carefully to insure a tight and wrinkle-free fit.
- The last step is installing the doors.

Allow yourself a few hours for the installation.

WINDSHIELD ADJUSTMENT

IMPORTANT: IMPROPER WINDSHIELD ADJUSTMENT WILL RESULT IN POORLY FITTING DOORS, MISLOCATED SNAPS AND A POOR FITTING TOP.

1. Measure from the top lip of the windshield to the rear of the body, not the tailgate. See Figure 1. Hook end of tape measure over the lip on the top of the windshield and take the measurement to the rear point of measurement on body. See Figure 2. Move about 6" over from the outside of the Jeep® before measuring, as shown in Figure 1. Be sure the measurement is true on both sides of the Jeep®.

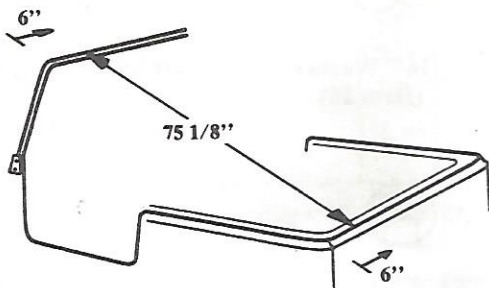

Fig. 1

2. Windshield adjustment should be made by loosening the two bolts in the windshield clamp. The distance should be adjusted to 75-1/8". See Figure 2.

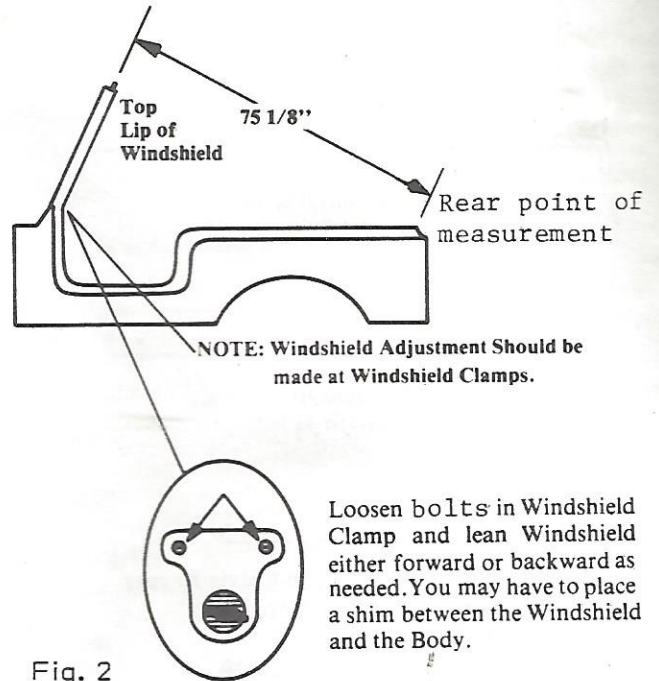

Fig. 2

A. INSTALL BOW MOUNTING BRACKETS

1. Mark the location for the front hole in each Bow Mounting Bracket by measuring 31 1/2" from the rear point of measurement on body. Mark with a pencil. See Figure 3.

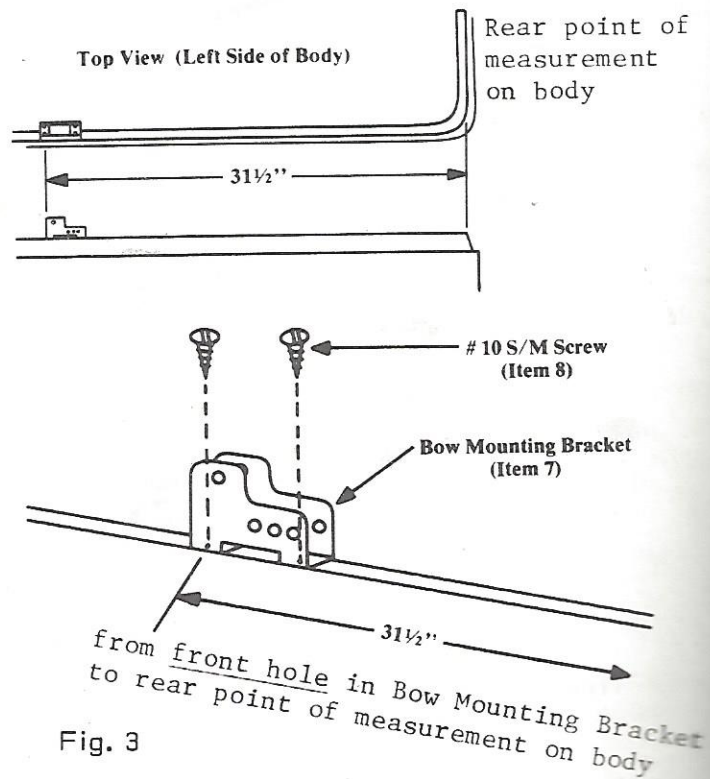

Fig. 3

2. With the Bow Mounting Bracket flush to the outside wall of the bed, use bracket as a template to mark the location of the rear hole.

IMPORTANT: Bracket secures to vehicle by using two Sheet Metal Screws in two holes only per bracket. Use the two holes in each bracket which are closest to the outer edge of the body.

3. Center punch the marks and drill 5/32" holes at these locations. Fasten Bow Mounting Bracket to the top edge of the body with two #10 Sheet Metal Screws. See Figure 3.

CAUTION: There may be wiring for the rear lights under the body edge. Pull wiring out of the way before drilling.

B. VERTICAL ROD MOUNTING

1. Make provisions for the Vertical Rods to mount at the rear of the door openings. Locate Vertical Rod Bracket on top edge of body behind door opening as shown in Figure 4. Use bracket as a template to mark the locations for the holes.

2. Drill 5/16" holes and secure bracket to vehicle with the 1/4" x 3/4" Bolts, 1/4" Lockwashers and 1/4" Nuts.

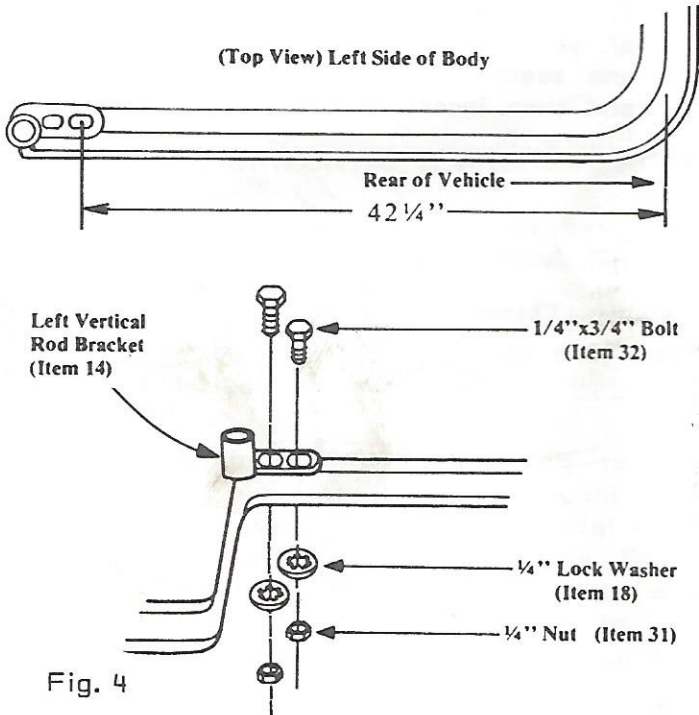

Fig. 4

C. HORIZONTAL ROD MOUNTING

1. Make provisions for the Horizontal Rod Bracket to mount to the windshield. Locate Horizontal Rod Bracket in the upper corners of the windshield frame, flush with the top of the windshield frame, as shown in Figure 5.

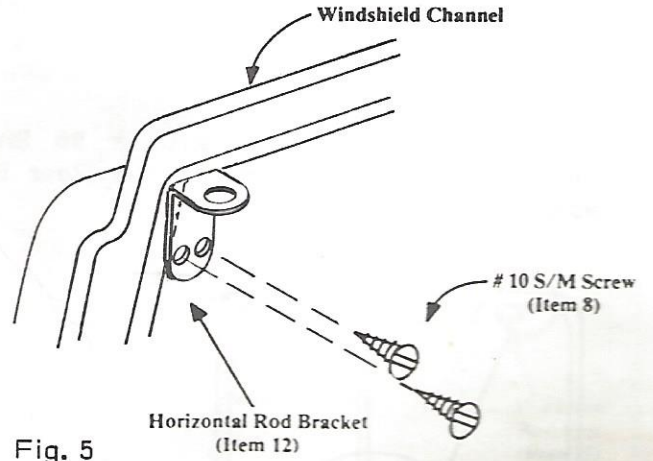

Fig. 5

2. Use bracket as a template to mark, center punch and drill 5/32" holes. Secure brackets to windshield with four #10 S/M Screws.

D. FRONT BOW ASSEMBLY

1. Assemble two halves of the Front Bow as shown in Figure 6. Slide a Bow Cover over each leg of the Bow. Be sure two large holes in Front Bow face the front of the vehicle.

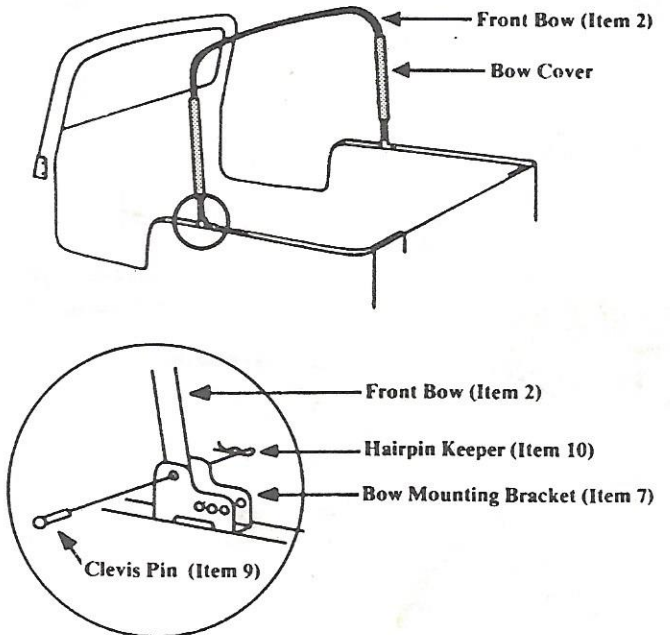

Fig. 6

2. Secure one leg of the front Bow to the Bow Mounting Bracket with a Clevis Pin and Hairpin Keeper as shown in Figure 6.

3. Spring the opposite Bow leg into Bow Mounting Bracket. [this should be approximately 3" to 4"]. Fasten leg with Clevis Pin and Hairpin Keeper.

E. REAR BOW ASSEMBLY

1. Install a Body Stud with a #6 Sheet Metal Screw in each hole in the Rear Bow as shown in Figure 7.

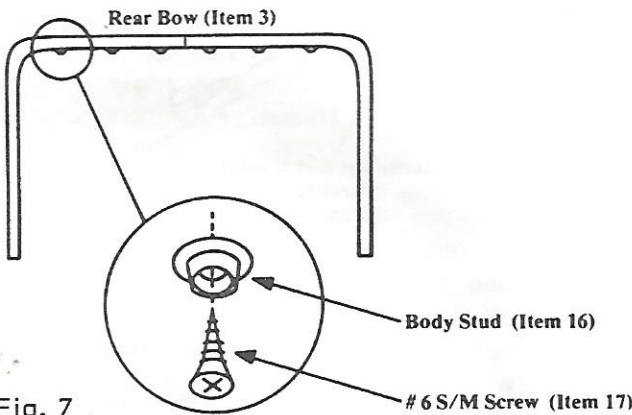

Fig. 7

2. Assemble two halves of the Rear Bow.

3. Slide a Bow Cover over each leg of the Rear Bow. Secure Rear Bow to Bow Mounting Bracket with a Clevis Pin and Hairpin Keeper as shown in Figure 8.

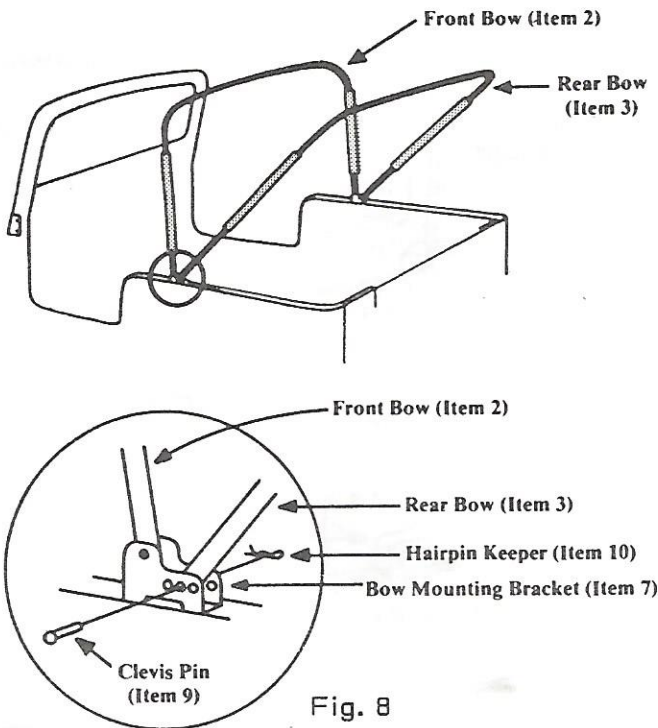

Fig. 8

NOTE: Attach Rear Bow to the center hole in the bracket. The other two holes adjust the tightness of Top after installation.

F. INSTALL WINDSHIELD CHANNEL

1. Center Windshield Channels on top of Windshield frame butting channels up against each other as shown in Figure 9. Use channels as a template to mark and drill 5/32" holes in vehicle. Secure channels to vehicle with six #10 Sheet Metal Screws.

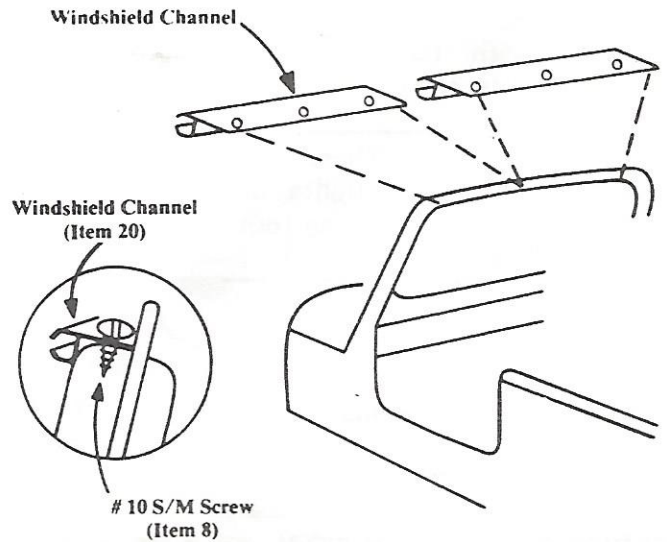

Fig. 9

G. TOP FABRIC INSTALLATION

1. Unfold Top, lay over Front Bow. Because of seam thickness, it is easier to take one seam to the outside of the channel, and then insert into channel groove. See Figure 10.

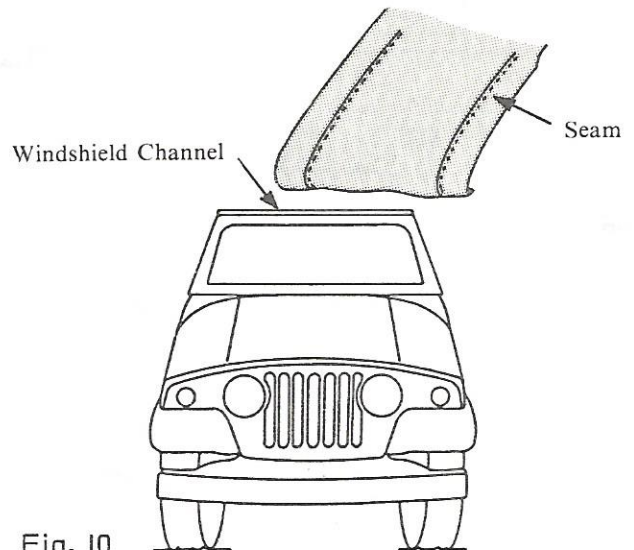

Fig. 10

Slide the whole Top towards the other side far enough so that the other seam is outside the channel. See Figure 11. Insert this seam in the same manner as the first one. Then stretch the Top and make sure is centered on the vehicle.

2. Lift the Rear Bow and place Top over it. Snap the flaps on the inside of the Top to the six Body Studs installed in E-1, on the Rear Bow.

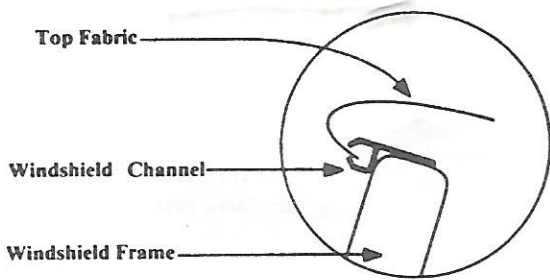
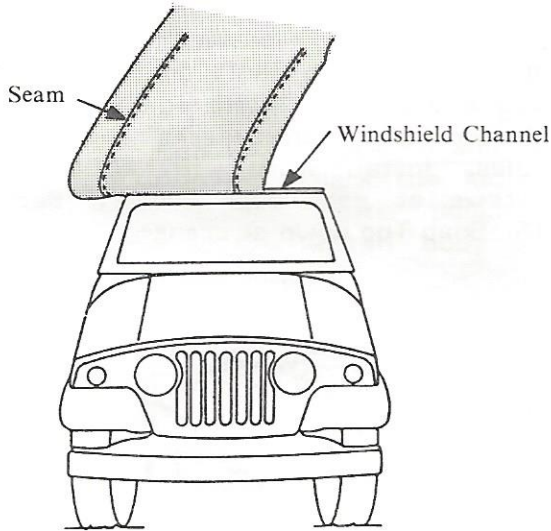

Fig. 11

H. INSTALL HORIZONTAL & VERTICAL RODS

1. Slide 1" Plastic Rod Caps over the straight end of each Horizontal Rod as shown in Figure 12.

2. Slide 1 1/2" Plastic Rod Cap over bent end of Horizontal Rod.

3. With the rod loops pointing to the inside of the vehicle, install bent end of Horizontal Rod into Horizontal Rod Bracket in windshield. Pull the Front Bow forward and insert the other end of Horizontal Rod into the hole on the corner of the Front Bow. Unfasten the

hook-and-loop strip over the door and refasten over Horizontal Rod.

4. Slide the 1 1/2" Plastic Rod Caps over the smooth end of the Vertical Rods and slide Vertical Rods up through fabric sewn into Top behind door openings. Slide plastic cap end up through rod loop of the Horizontal Rod as shown in Figure 12. Set the bottom of the Vertical Rods into the 3/8" holes in the body.

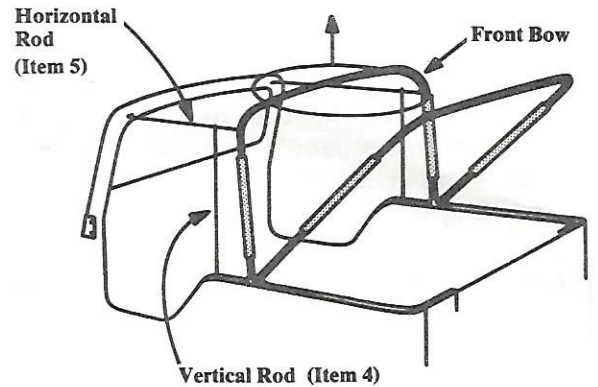
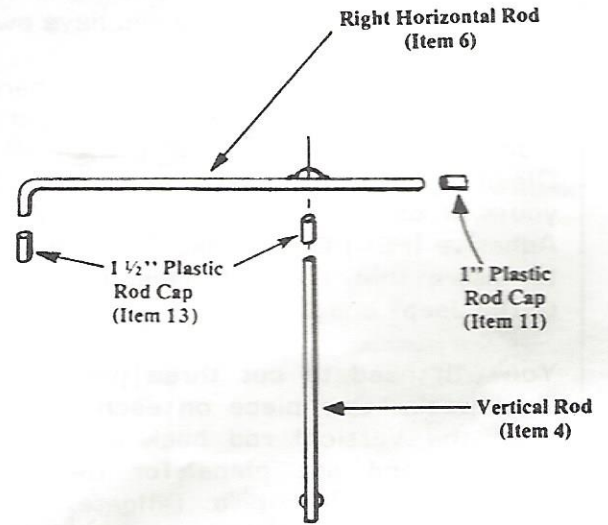

Fig. 12

4. Attach fasteners around front Bow as shown in Figure 13.

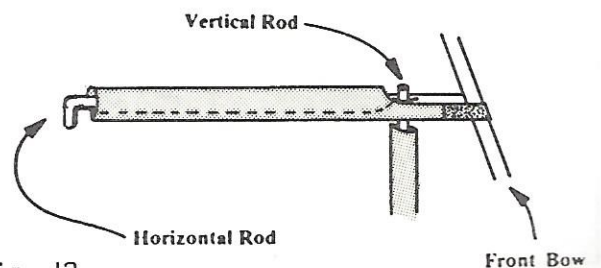

Fig. 13

I. INSTALLING BODY STUDS

#51008

For the "Royal Craftsman"® Top Only

The installation of this Top is the same as our standard Convertible Top, with the exception of the hook-and-loop fastening system, in addition to the snaps to secure the Top to the Jeep® body.

Once you have finished installing your new Royal Craftsman Top, we are certain you will notice how much quieter and airtight it is than any other soft top you have owned.

After you have installed the new hardware on your Jeep®, remove all the old studs from the sides and rear of the Jeep® body. Clean the body surface thoroughly where you will be applying the Pressure Sensitive Adhesive (PSA) Dual Lock. This is important to insure that the PSA Dual Lock adheres to the Jeep® body.

You will need to cut three pieces of PSA Dual Lock. One piece on each side to run from the Vertical rod back around to the tailgate, and one piece for the tailgate. (On models without a tailgate, you can use one continuous piece).

Peel the backing from the PSA Dual Lock as you go and press it firmly onto the Jeep® body. Position the PSA Dual Lock so that it is centered in the notch along the top edge of your Jeep® body. Make sure the PSA Dual Lock is stuck securely before installing the Top.

After installing the Top and fastening it to the PSA Dual Lock, mark and drill the holes for the studs to match up with snaps on the Top as stated in instruction "I". Drill right through the PSA Dual Lock.

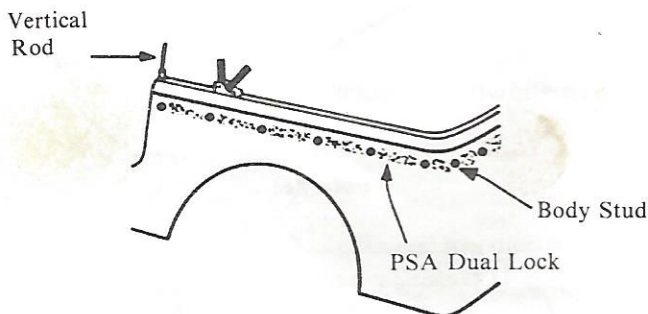
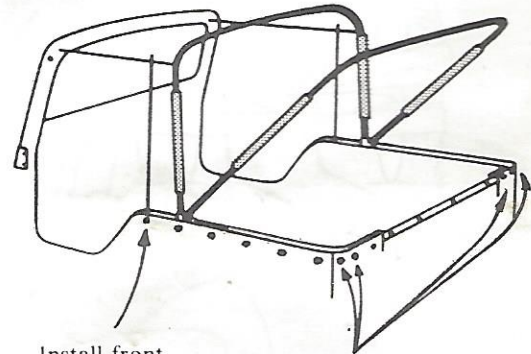

Fig. 14

The next five steps are very important in the installation of your Top. In order to do them you will need the help of another person to pull down on the Bow and Top fabric. Make sure the Top is as warm as possible. The first corner snaps are the most important for a tight and wrinkle-free fit.

1. Close all zippers on side and rear curtain before installing Body Studs.

2. Starting at the rear corners of your Jeep®, mark the locations for the two corner studs by rubbing chalk on the snaps in the Top and pressing them against the vehicle. Center punch the marks and drill 3/32" holes. Install studs with #6 Sheet Metal Screws at each rear corner. See Figure 15. Snap Top down at corners.



Install front corner stud here next, both sides.

Install two corner studs here first, both sides.

Fig. 15

NOTE: To insure a good fit, have another person pull down on the Rear Bow while you pull the fabric **DOWN AND TO THE REAR** to locate the two rear studs. If pulling the fabric into position is extremely difficult, tightness can be adjusted by moving the Rear Bow into the front hole in the Bow Mounting Bracket. If curtain remains loose when pulled into position, move the Rear Bow into the back holes in the Bow Mounting Bracket.

3. Next, move to the front of the side panels. Install studs with #6 Sheet Metal Screws next to the door openings. Pull the Top fabric down and forward to eliminate wrinkles and insure a proper fit. Install studs here and on the opposite side.

4. Install remaining studs to match up with remaining snaps in the side panels, tailgate and windshield frame by using the chalk process. Be sure to alternate from side to side to eliminate wrinkles. Snap Top to each new stud to spread the tension evenly.

5. There is a snap on each front corner of your Top. Pull fabric forward and down to eliminate wrinkles. Mark the locations for the Body Studs. Center punch and drill 3/32" holes and install body Studs with #6 Sheet Metal Screws.

J. INSTALLING DOORS

1. Mount Door Pivots to the outside of the Door as shown in Figure 16, with the 1/4" Lockwashers and 1/4" x 1/2" Bolts. You will need to punch holes in the fabric. Leave Bolts loose in order to adjust Doors to a proper fit.

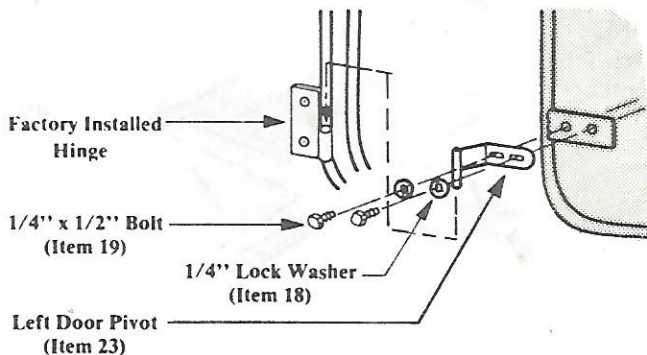
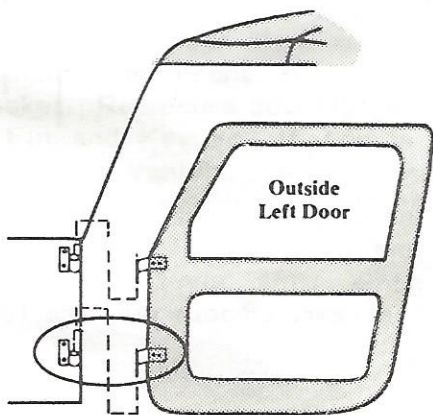

Fig. 16

2. Install Doors by sliding Door Pivots down into the door hinges of the vehicle. Adjust for fit and tighten bolts.

3. Repeat steps 1 and 2 for opposite door.

4. Assemble Door Handles as shown in Figure 17 (left door). Press handles firmly together and tighten the set screw in the outside handle with a 3 mm Allen Wrench. Tension of Door may be adjusted by bending handle.

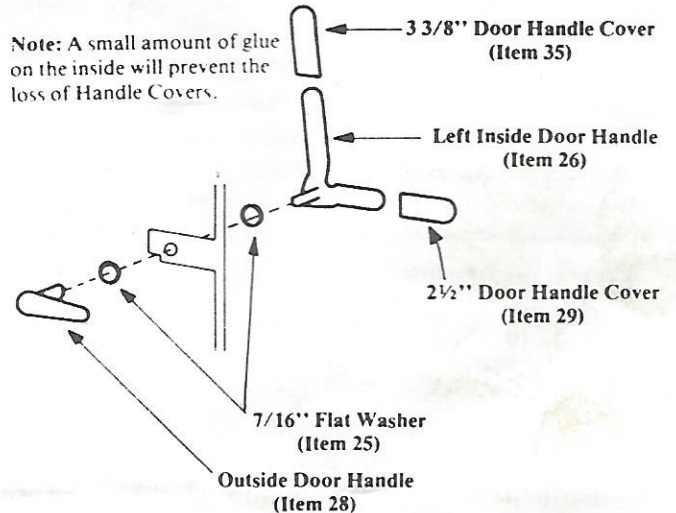

Fig 17

5. Unzip door windows and close Door. Put your head inside the window and look for gaps between Doors and body. By bending the door frame a small amount at a time and checking the door sealing after each bend, you will be able to form the door frame to the contour of the body. Finally slide the small plastic Zipper Tab Covers over Zipper Tabs to quiet their rattling. A small amount of glue on the inside will prevent the loss of Zipper Covers.

#51008

K. TO ROLL SIDES AND REAR CURTAIN

1. The rear curtain and side panels may be rolled up and secured to the inside of the Top Fabric. To roll the rear curtain, begin at the bottom and then roll to the inside avoiding wrinkles in the fabric and the vinyl windows. See Figure 18.

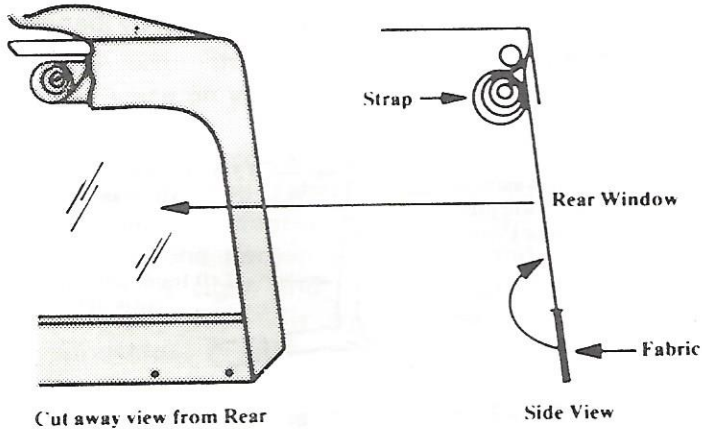

Fig. 18

2. To roll back the side panel, first remove the Vertical Rod and unzip the side panel. Roll panel to the inside and to the rear as shown in Figure 19. Secure panel with straps on the side panel.

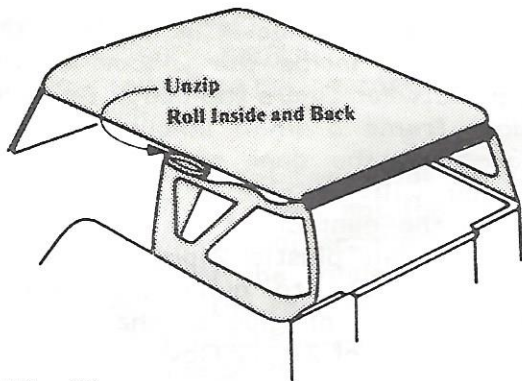

Fig. 19

L. FOLDING TOP DOWN

1. Open rear curtain zippers and unsnap rear and side panels. Remove Vertical and Horizontal Rods. Unfasten the Top from the Front Bow. Push the Front Bow back toward the Rear Bow.

2. Fold the side panel windows in half along the diagonal seam that separates the two window sections. See Figure 20.

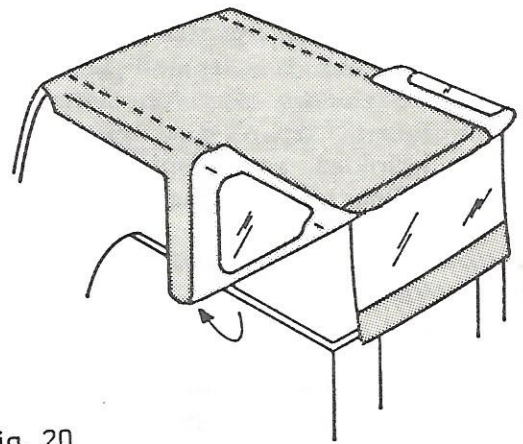

Fig. 20

3. Lay the folded side panel up over the top, folding along the heat-seal seam. This eliminates creases in the windows. Then fold the rear curtain up over the side panels. See Figure 21.

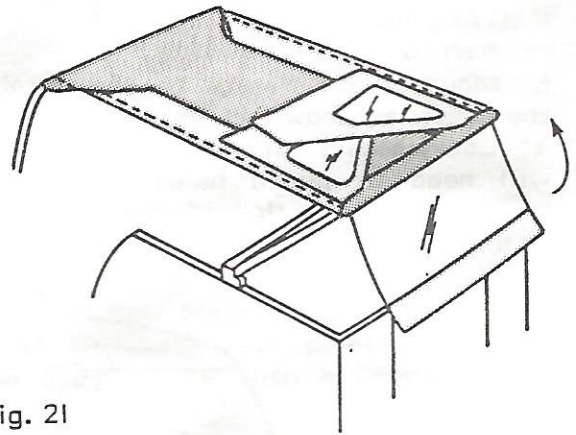

Fig. 21

4. Unfasten the Top from the windshield and lower the Top on the vehicle, at the same time pivoting both bows down to the rear, smooth out side folds. See Figure 22.

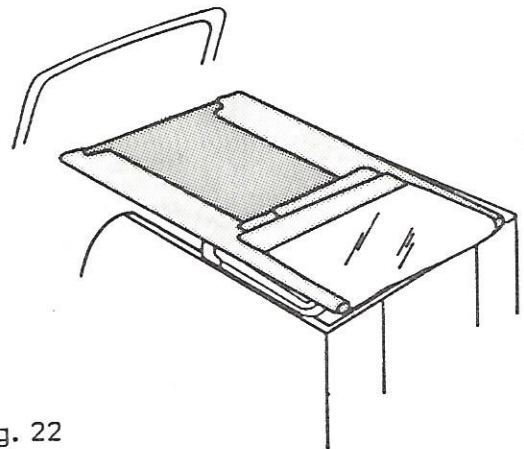

Fig. 22

#51008

5. Fold the Top in half from front to rear. See Figure 23.

M. FOLDING FOR STORAGE

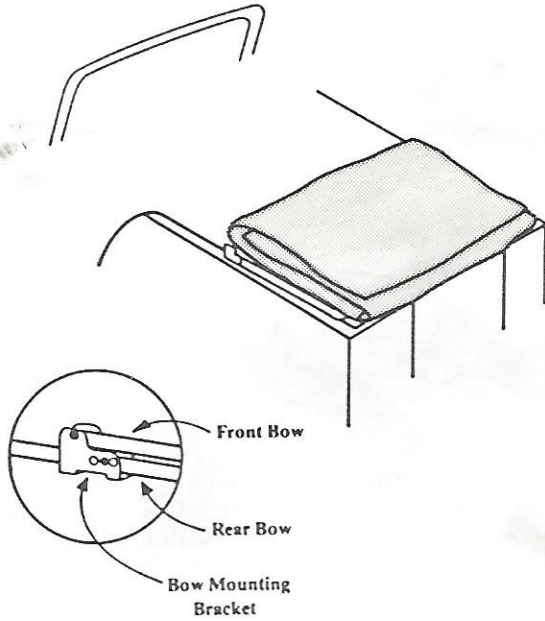

Fig. 23

NOTE: When folding for storage, place sheets of paper on each side of each window to protect from scratching.

1. Folding can be done on the vehicle or on a clean dry surface. Follow Figures 20 through 23 of the Fold Down Instructions, then fold the Top in half side to side. Lay the Vertical and Horizontal Rods in the bottom of the original carton. Place the Top fabric between the outside surface of the doors (metal side of door to the outside), then pick up the Top and doors as a unit and place them in the carton. Lay the two Bows on each side of the Top and close the carton. Store in a cool, dry area.

If Top is to be kept on vehicle, roll carefully toward the rear and store in a Top Boot, or fasten securely with a nylon rope or straps. Leave attached to Rear Bow. If you do not want the Rear Bow laying on the spare tire, you may remove the Clevis Pin and Keeper from Rear Bow and slide Rear Bow under the Front Bow in the mounting bracket. Re-secure bow to bracket with Clevis Pin and Keeper. If Top is to be removed from vehicle, unsnap from Rear Bow, and fold in half from side to side. See storage instructions.

Should you find it necessary to return your Top, follow instructions as described in Folding for Storage. Be sure to wrap and tape ends of rods and bows to prevent sharp corners from tearing fabric. Place hardware in original bag and seal securely. Please take a moment to explain why you are returning this Top. Include this manual in carton and seal securely.

Reason for Return: _____

Care & Maintenance

Your Top is made of the finest materials available. To keep it looking new and for the maximum possible wear, it will need periodic cleaning and maintenance.

Washing: The Top fabric should be washed often using soap, warm water and a soft-bristle brush. Rinse with clear water to remove all traces of soap. A Vinyl protector can be used on vinyl side of the Top Fabric.

Windows: Keep Windows clean to avoid scratching. DO NOT use a Brush on the Windows! Wash with a watersoaked cloth or sponge and a mild dishwashing detergent. NEVER WIPE WINDOWS WHEN THEY ARE DRY. Be careful when cleaning snow or frost from the vinyl windows since they are easily scratched and may crack at low temperatures. DO NOT Roll the Sides or Rear Curtain in cold weather. The windows become stiff and will crack.

Zippers: Keeping the Zipper cleaned and lubricated with a silicone lubricant will help prevent damage and keep Zipper in a smooth working condition. If a Zipper remains open behind a slider, the slider may have been spread apart. This problem can usually be repaired by using an ordinary pair of pliers to bring the sides back into parallel. Return Slider to end of Zipper in normal Open position. Squeeze lightly at first and test the Zipper. If the zipper continues to remain open squeeze more firmly with pliers and try the zipper again. Repeat this procedure until the zipper operates correctly.

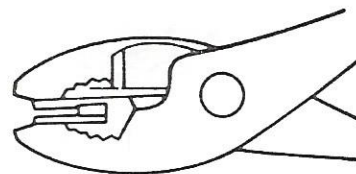
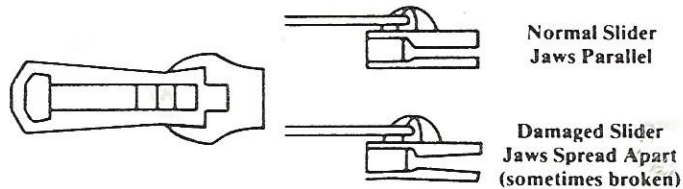

Water: Seeping through at the seams may be stopped by applying 3-M Scotchgard® on the inside of the seams. Rips in the Fabric may be repaired with Bondex® iron on patches. Iron the patches to the Inside of the Top, carefully following the Bondex® instructions.

Snaps: Keep Snaps cleaned and lubricated with silicone to help prevent snaps from sticking to the Studs. If a Snap does become stuck to a Stud, use a screwdriver and GENTLY pry apart to prevent permanent damage to the Snap or the Top Fabric.

LIMITED WARRANTY

We warrant our products to be free from defects in material, for the terms specified below, provided there has been normal use and proper maintenance. This warranty applies to the original purchaser only. All remedies under this warranty are limited to the repair or replacement of any item or items found by the factory to be defective within the time period specified.

If you have a warranty claim, you must send the defective item freight prepaid to our factory at the address specified below. You must retain proof of purchase and submit a copy with any items returned for warranty work. Upon completion of warranty work, if any, we will return the repaired or replaced item or items to you freight prepaid. Damage to our products caused by accidents, fire, vandalism, negligence, abuse, misuse, Acts of God, or by defective parts not manufactured by us, is not covered under this warranty.

THE TERMS OF OUR WARRANTY ARE AS FOLLOWS: ALL "SOFT GOODS" MANUFACTURED BY OUR COMPANY (USING PRIMARILY VINYL, PLASTICS, AND/OR FOAM): 90 DAYS FROM DATE OF PURCHASE.

ANY IMPLIED WARRANTIES OF MERCHANTABILITY AND OR FITNESS FOR A PARTICULAR PURPOSE CREATED HEREBY ARE LIMITED IN DURATION TO THE SAME DURATION AS THE EXPRESS WRITTEN WARRANTY. OUR COMPANY SHALL NOT BE LIABLE FOR ANY INCIDENTAL OR CONSEQUENTIAL DAMAGES.

Some states do not allow limitations on how long an implied warranty lasts, or the exclusion or limitation of incidental or consequential damages, so the above limitations or exclusions may not apply to you.

This warranty gives you specific legal rights, and you may also have other rights which vary from state to state.

For further information or request for warranty work, please contact:

WYNN'S AUTOMOTIVE
PRODUCTS, INC.
P.O. Box 1119
Longmont, CO 80501
(303) 776-1630
TWX 910-320-0785



TWENTY-FOUR MONTH LIMITED WARRANTY

Bestop/Dualmatic, Inc., warrants to the original purchaser only that its Royal Craftman soft top (the "top") will be free from defects in material and workmanship for two years from the date of purchase, provided there has been normal use and proper maintenance. This warranty shall not cover damage caused by accident, fire, vandalism, negligence, abuse, misuse or Acts of God. All remedies under this warranty are limited to the repair or replacement, as set forth below, of any top found to be defective within two (2) years from the date of purchase.

REPAIR

If, in the opinion of Bestop/Dualmatic, the damage to the top cannot be repaired in a reasonably acceptable manner, Bestop/Dualmatic will arrange for the top to be repaired at no charge to the purchaser.

REPLACEMENT

If, in the opinion of Bestop/Dualmatic, the damage to the top cannot be repaired in a reasonably acceptable manner, Bestop/Dualmatic will replace the top as follows:

a. If the damaged top is returned within the first ninety (90) days of purchase, Bestop/Dualmatic will replace the top at no charge to the purchaser.

b. If the damaged top is returned after the first ninety (90) days of the warranty period has elapsed, Bestop/Dualmatic will replace the top at a prorated charge to the customer determined by multiplying the original purchase price times the number of months which have elapsed during the warranty period divided by twenty-four months.

EXAMPLE:

Return the damaged top to the dealer one year after purchase. A replacement top may be purchased from Bestop/Dualmatic at 50% of the price paid the dealer originally.

$$\frac{12 \text{ Months Since Purchase}}{24\text{-Month Warranty Period}} \times \text{Original Purchase Price} = \text{Price of Replacement Top}$$

CLAIM PROCEDURE

If you have a warranty claim, contact the dealer which sold the top. The dealer and Bestop/Dualmatic will determine whether the damage can be repaired or the top must be replaced. Retain proof of purchase and submit a copy with any damaged tops returned for warranty work.

If you cannot contact the selling dealer, contact Bestop/Dualmatic directly at:

Bestop/Dualmatic Inc., Warranty Department
Post Office Box 1119, Longmont, Colorado 80501
(303) 776-1630

TO THE EXTENT PERMITTED BY LAW, ANY IMPLIED WARRANTIES OF MERCHANTABILITY AND/OR FITNESS FOR A PARTICULAR PURPOSE CREATED HEREBY ARE LIMITED IN DURATION TO THE SAME DURATION AS THE EXPRESS WRITTEN WARRANTY. BESTOP/DUALMATIC INC., SHALL NOT BE LIABLE FOR ANY INCIDENTAL OR CONSEQUENTIAL DAMAGES.

Some states do not allow limitations on how long an implied warranty lasts, or the exclusion or limitation of incidental or consequential damages, so the above limitations or exclusions may not apply to you.

This warranty gives specific legal rights, and you may have other rights which vary from state to state.

To Validate your warranty, please fill in the information requested and return this portion to:

Bestop/Dualmatic Inc.
Post Office Box 1119
Longmont, Colorado 80501

Name: _____ Vehicle Model _____ Year _____

Address _____ Model No. of Top _____

City _____ State _____ Zip _____

Where did you purchase your top? _____

Dealer's Name _____

City _____ State _____ Zip _____